

# SLA

FACTORY ACTIVATED

SLA | READY TO START

## REF BB10L-B2



**12V** VOLTAGE - V

**120A** CCA - A

**11.6Ah** CAPACITY - Ah (20Hr)

**11Ah** CAPACITY - Ah (10Hr)

### TECHNOLOGY

- Designed according to AGM technology (Absorbed acid)
- VRLA battery type
- Activated and pre-charged batteries
- Homologated by OEM

### FEATURES

- AGM construction (Absorbed Glass Material)
- VRLA battery (Valve Regulated Lead Acid)
- Factory activated
- Environmentally friendly, spillproof design
- Multi-positional fitment
- Absolutely Maintenance free
- Sealed, no gas emission through venting hole (under normal operation)
- Ready & Easy to use
- No acid handling - Very safe
- Increased power & Extended life
- Extreme vibration resistance

### UPGRADE FOR

### WEIGHT

Battery (with acid) : Approx 3.78kg (8.32 lbs)

### MOUNTING ANGLE

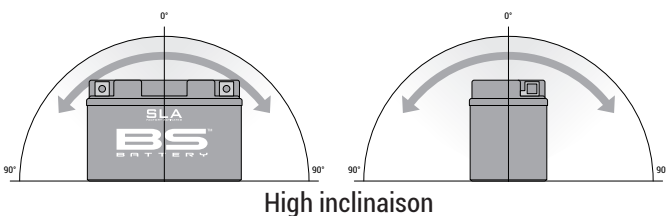

### DIMENSIONS

Length (A) : 133±2mm (5.24 in)  
 Width (B) : 90±2mm (3.54 in)  
 Container height : 145±2mm (5.41 in)  
 Total height (C) : 145±2mm (5.41 in)

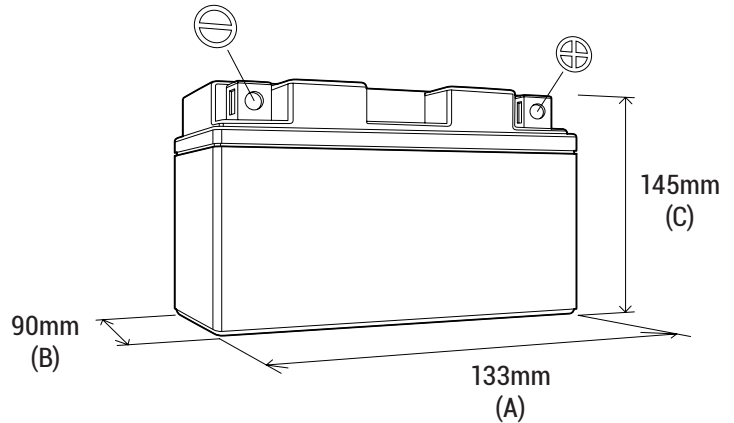

### TERMINALS

